

Sports Car Club of America (SCCA)
Southern Pacific Division ~ Arizona Region

SPEC RX-7 CLASS RULES

Effective: **January 1, 2014**

1. GENERAL

Spec RX-7 racecars are intended to be dual-purpose street and race vehicles. The class was conceived with the intention that costs be kept low while allowing close racing. To this end, these rules will be vigorously enforced at all SCCA-sanctioned events. These rules are absolute. They are not intended to be a guide to car preparation. Unless specifically mentioned or approved in these rules, no additional vehicle modifications may be made. Any sections referring to the SCCA General Competition Rules (GCR) or the Improved Touring Category Specification (ITCS) rules that have been affected by an updating of those books, the most current versions of the GCR and ITCS rule books apply. Current changes are shown in bold type. This final approved rule set for 2014 supersedes all previous rule sets.

2. MAKE OF CAR

Mazda RX-7, 1981-1985, equipped with 12A rotary engine. G, GS, or GSL trim-level models are eligible.

3. PREPARATION RULES

Minimum weight is 2480 pounds with driver.

1. Allowed Replacement Parts

Many of these items are available from Mazdaspeed Motorsports Development at 800-435-2508, comppart@mazdausa.com, www.mazdaspeedmotorsports.com. All drivers should register with them in order to purchase Mazda Original Parts at a discount.

1. Shock absorbers

Brand: Tokico High Performance Gas

Model: Front #HZ-1 069, Rear #HE-231 7

Notes: Non-adjustable, blue body

2. Sway bars

Brand: Suspension Techniques

Model: 52170 is the current part number as of 2001 (3-054 was the old number).

Notes: Front: 1 1/8" fixed. Rear: 5/8", adjustable. In the rear you may use the allowed replacement Suspension

Techniques sway bar, any 1981-1985 12A model RX-7 stock sway bar or no sway bar at all.

3. Springs

Brand: TMC or Progress Group.

Model: TMC PN is CSM-400 "Street/Race" and Progress Group PN is 40.1150.

Notes: TMC: Blue or Black color, Progress Group: Turquoise color.

4. Air filter

Brand: K&N Engineering, Inc.

Model: E-2700.

5. Engine drive pulleys

Brand: Mazda

Single Belt Underdrive System

Part

Mazda Part #

Sports Car Club of America (SCCA)
Southern Pacific Division ~ Arizona Region

SPEC RX-7 CLASS RULES

Effective: **January 1, 2014**

E-Shaft Pulley 0000-01-7201

Water Pump Pulley 0000-01-7211

Alternator Pulley 0833-78-153A

Brand: Mazdatrix or Racing Beat

Dual Belt System

Part	Part #
------	--------

E-Shaft pulley	11479
----------------	-------

Alternator pulley	11469
-------------------	-------

Note: Visit <http://www.mazdatrix.com/FAQ/PULLEY.HTM> for critical information on E-shaft pulley replacement.

6. Fan clutch and fan

May be removed and replaced with an electric fan. The shroud is not required.

4. Tires

1. Brand: Yokohama - Size: 205/60R13

5. Safety Equipment

The SCCA GCR safety rules for driver's restraint system (9.3.19), fire extinguisher (9.3.25) window net (9.3.54) apply. The ITCS rules, Sections 9.1.3.D.10a,-b and 9.1.3.D.10d-g are applicable for all other safety items.

1. Roll cage: Brand, Autopower Industries, Inc., model RX-7, PN 83591 made of 1-1/2" DOM material. ERW cages are grandfathered if the logbook was issued before 12/31/02. Material and construction defined by the SCCA GCR Sections 9.4.1 and 9.4.2.

2. All cars must use the specified roll cage which shall not be modified, except for mounting a window net, seat belt mounting brackets, and will only be bolted in place.

1. Early model roll cages must be modified to adhere to the GCR, Section 9.4.2.D.1, full horizontal bracing.

2. Outer dash vent louvers may be removed for roll cage clearance where needed.

3. Steering wheel lock must be removed.

6. Interior

1. The interior may be modified only as follows:

1. Driver's seats shall be replaced with any aftermarket racing seat per the GCR ITCS, Section 1.7.1.4.D.9.a. Driver's seat back must be braced per the GCR, Section 9.3.40 and head restraint per the GCR, Section 9.4.1B. Passenger seat, if replaced, must meet the same criteria as driver's side racing seat, including mounting procedures. Both driver's and passenger's seats are required.

2. Any steering wheel may be used, per the GCR ITCS, Section 9.1.3.D.9.b.

3. The radio, amplifier, and speakers, the ashtray, cigarette lighter and clock may be removed. Any shift knob may be used.

Sports Car Club of America (SCCA)
Southern Pacific Division ~ Arizona Region

SPEC RX-7 CLASS RULES

Effective: **January 1, 2014**

4. Gauges may be added, but shall only be installed in the center console area previously occupied by radio equipment. Shift lights may be installed and mounted in any convenient location for the driver.
5. Inside door handles and armrest assembly/door pocket box may be modified or removed for roll bar clearance. The remaining stock door trim panel must be retained and may be recovered to hide holes or account for wear. If the door pocket/armrest assembly is removed, the door panel must be recovered to present a uniform appearance. Trimming the height or replacement of the door panel sub-structure with alternate materials is not allowed.
6. The heater core may be disabled or removed.
7. To facilitate seatbelt mounting, the stock driver's side seatbelt may be removed.
8. The stock interior mirror may be replaced with any aftermarket unit.
9. All interior trim, carpeting and sound deadener can be removed except for the dashboard, shifter surround and door panels.
2. If ballast must be added to bring the car up to minimum weight, it must be securely fastened to the floor of the passenger foot well or under the passenger seat. Refer to the GCR ITCS for ballast.
3. Alternate pedal covers and extensions are permitted.
7. E. Exterior
 1. Cars may be repainted in non-factory colors.
 2. Any exterior mirrors may be used provided they are functional and fitted in the stock location.
 3. Fender openings may be modified for tire clearance per the GCR ITCS, Section 9.1.3.D.8.a.
 4. Emblems, side moldings, side-marker lights and related parts, turn indicators and related assemblies may be removed.
 5. Holes created by this removal may remain open or be used for air ducting as long as nothing protrudes beyond the body or outer portion of the bumper. Headlight sealed beams may be removed.
 6. Lexan replacement windshields are authorized providing they meet the following minimum specifications. Refer to CGR Production Category Specifications (PCS), Section 9.1.5.D.9.a.8. Windshield clips and hood pins may be added per the GCR ITCS, Sections 9.1.3.D.8.d and e.
 7. The radio antenna may be removed. The remaining hole must be covered.
8. Engine
 1. All engine electrical components must remain stock and unmodified, with the following specifically allowed modifications:
 1. Any spark plugs may be used.

Sports Car Club of America (SCCA)
Southern Pacific Division ~ Arizona Region

SPEC RX-7 CLASS RULES

Effective: **January 1, 2014**

2. Any brand of spark plug wires may be used of 9mm diameter or less, providing they are of the original single-wire resistance type and do not include external grounding wires or any means of charge or spark boost.
 3. Ignition coils may be replaced with any coils that will mount in the stock location.
 4. Ignition timing shall be stock (per manufacturer's specifications). See the Ignition Timing Diagram, figure 1.
 5. Distributor must remain unmodified.
 6. All emissions equipment may be removed including the catalytic converter. Any equipment not removed must either be disabled or left to function as originally intended by the manufacturer. All disconnected ports and holes must be plugged. The shutter-valve may be wired open, but may not be modified in any other way. The external shutter-valve actuator may be removed. Ported vacuum lines can be added for distributor advance.
2. Engine and drivetrain lubricants are free.
 3. Cooling system must remain operable and unmodified, with the exception of the following specifically allowed modifications:
 1. Radiator may be replaced with a larger unit of the same type and material as the original, and must mount in the original, unmodified location.
 2. 1983 and later cars may use the earlier oil cooler system, providing the early radiator is used.
 3. 1981 and 1982 cars may use the later oil cooling system, providing the later radiator is used.
 4. Engine drive pulleys, fan and fan clutch may optionally be modified as per section III, A5 and A6 above.
 4. Stainless steel braided oil lines may be used for oil cooler.
 5. A screen may be installed in front of the radiator and oil cooler to help prevent stone damage.
 6. Air conditioning, cold start assist system, and cruise control components in the engine compartment may be removed.
 7. Fuel system, including tank and filler, must remain unmodified, with the exception of the following specifically allowed modifications:
 1. Fuel pumps and fuel pressure regulators are free. Regulators may be installed anywhere in the fuel delivery line to the carburetor. Replacement fuel pumps must be mounted within 12" of the original location.
 2. The fuel tank return line shall remain as stock and shall not be used for fuel delivery to the carburetor.
 3. The stock fuel-return check valve and fuel tank rollover valve may not be modified, bypassed or removed.

Sports Car Club of America (SCCA)
Southern Pacific Division ~ Arizona Region

SPEC RX-7 CLASS RULES

Effective: **January 1, 2014**

4. Any fuel filter(s) may be used
5. A fuel sample acquisition valve/port shall be installed per the GCR, Section 9.3.25.B.
8. Carburetor must remain stock and unmodified except for the following specifically allowed modifications:
 1. "Grose Jet" carburetor needles and seats may be used in place of stock carburetor needles and seats, providing the replacements are of identical size to stock.
 2. The shutter-valve system may be disabled and the external actuator removed; however the shutter-valve butterfly may not be removed or modified.
9. Electrical charging system must be functional and operating as per manufacturer's specifications.
10. Battery must be as stock, Group 24, 24F, or 24R, and mounted in the original location. Minimum battery dimensions are H 7¼", W 6½", L 9¾". Minimum battery weight is 24 pounds. A 12Volt, "Gel Cell" type battery may be used as long as it is at least the same weight (24 pounds).
9. Exhaust
 1. The main catalytic converter may be removed, gutted or replaced by any EPA or CARB approved aftermarket converter. The converter fresh air system & pipe must be retained and vented to atmosphere or connected to converter. The inlet and outlet of the converter (if used), may be no larger than 2¼" O.D. The pre-converters may be removed and replaced with 2¼" O.D. pipe.
 2. Exhaust must follow the stock routing (over the axle), and must exit from the stock location and extend to the rear bumper.
 3. Maximum outside diameter for exhaust pipe is 2¼" O.D.
 4. A muffler is not required. All vehicles must meet sound standards per the SCCA GCR, Section 5.7. Any muffler may be fitted as long as the inlet and outlet diameters are no larger than 2¼" O.D. and tailpipe diameter is 2¼" O.D. maximum.
 5. The upper and lower exhaust system heat shields may be removed.
10. Drivetrain
 1. Any stock style pressure plate and disc may be used, provided the replacement is the same weight or greater than original.
 2. All vehicles not originally equipped as such may be fitted with the entire rear-end assembly from a GSL model (disc brakes and limited slip differential).
 3. The differential ratio must be 3.9:1, using stock 81-85 Mazda RX-7 factory gears.
 4. No modifications to the stock differential are allowed.
 5. The stock wheel lug-bolt system may be replaced with wheel-studs and nuts.
 6. Transmission must remain stock.
11. Brakes
 1. Any brake pad material or brake fluid may be used.
 2. Braided steel brake lines may be used.

Sports Car Club of America (SCCA)
Southern Pacific Division ~ Arizona Region

SPEC RX-7 CLASS RULES

Effective: **January 1, 2014**

3. Adjustable brake-bias valves are allowed and may be installed in addition to, or as a replacement of, the stock valve, but must be installed in the engine compartment and must not be driver adjustable from the cockpit.
 4. If rear disc brakes are installed on a vehicle not originally equipped with rear disc brakes, the master cylinder and proportioning valve from a disc-brake car may be installed. Otherwise, the brake master cylinder must remain unmodified.
 5. Front brake dust-shields may be modified or removed.
 6. Brake cooling is allowed per the GCR ITCS, Section 9.1.3.D.6.b. Ducts of 3" maximum diameter may be used for brake cooling.
 7. The plastic inner fender panels may be removed or modified.
12. Suspension
1. Upper strut mounting holes may be slotted for increased camber/castor. Upper center strut locating hole may be modified to facilitate strut movement. Stock strut hat must be used and cannot be modified for clearance.
 2. All suspension bushings must remain stock and unmodified, with the following exceptions:
 1. Urethane front control arm bushings (Energy Suspension part #11-3101) may be used.
 2. Urethane strut rod bushings (Energy Suspension part #11-7101) may be used.
 3. Rear axle bump stops may be modified, removed or replaced.
 4. Stock rear sway-bar end links may be replaced with Energy Suspension part #9-8123.
 5. Front suspension rubber coil spacers may be removed.
 3. A maximum of two spacers (Mazda part #1011-34-013) may be added per side to the front strut assemblies for weight balancing.
 4. One "stayrod" may be added for chassis stiffening between the front upper strut towers per the GCR ITCS, Section 9.1.3.D.5.d.5.
 5. Minimum ride height is 4½". On a smooth and level surface, lift, bounce or manipulate until satisfied. Roll forward three feet, let settle for 30 seconds and measure minimum clearance of 4½" at the front cross-member, without the driver.
 6. Front wheel negative camber shall not exceed 1¼ degrees. No adjustments are allowed to the rear axle.
 7. Any brand or combination of 13" diameter wheel, alloy, stock factory or steel, up to 7" wide maybe used.
 1. Wheel back spacing shall be between 3½" and 4½". Back space is measured according to Figure 2.
 2. Minimum weight for wheel, tire, and lug nuts is 26 lbs.
 8. Wheel spacers may not be used.
13. Updating and Backdating

Sports Car Club of America (SCCA)
Southern Pacific Division ~ Arizona Region

SPEC RX-7 CLASS RULES

Effective: **January 1, 2014**

1. Exterior body parts, interior trim, engine, drive shaft and rear axle may be exchanged or replaced with that of another year, so long as the parts are 1981 to 1985, 12A model vehicles.
 2. Any component updating or backdating must be done as an entire unit.
14. “No-Touch” Rule
1. The following components, or any part thereof, may not be modified, detailed or massaged in ANY way:
 2. Engine (including intake or exhaust ports and all internal moving or stationary parts)
 3. Transmission
 4. Carburetor (except as allowed in Section III, F, 8).
 5. Intake manifold and exhaust manifold.
15. Onboard Data Acquisition, Video and Radio Systems
1. Lap timing, lap counting or data acquisition systems may be fitted to the vehicle and used during any practice, qualifying or race session.
 2. Video recording is allowed.
 3. Two-way radio systems may be used.
16. Rules Freeze
1. These rules are “frozen” until a two-thirds majority vote approves change. Eligible voters are current car-owner members only. The intent is to eliminate “rules-creep” with small, but continuous, year to year changes. Amendments to these rules for the purpose of updating or correcting inconsistencies, ambiguities, and technical data such as supplier part number revisions are to be accomplished without the two-thirds majority vote process. Those type amendments are to be reflected in this document as soon as practical. The SCCA General Competition Rules are the official guideline for Club Racing and supercede these rules should there be conflict.

**Sports Car Club of America (SCCA)
Southern Pacific Division ~ Arizona Region**

SPEC RX-7 CLASS RULES

Effective: January 1, 2014

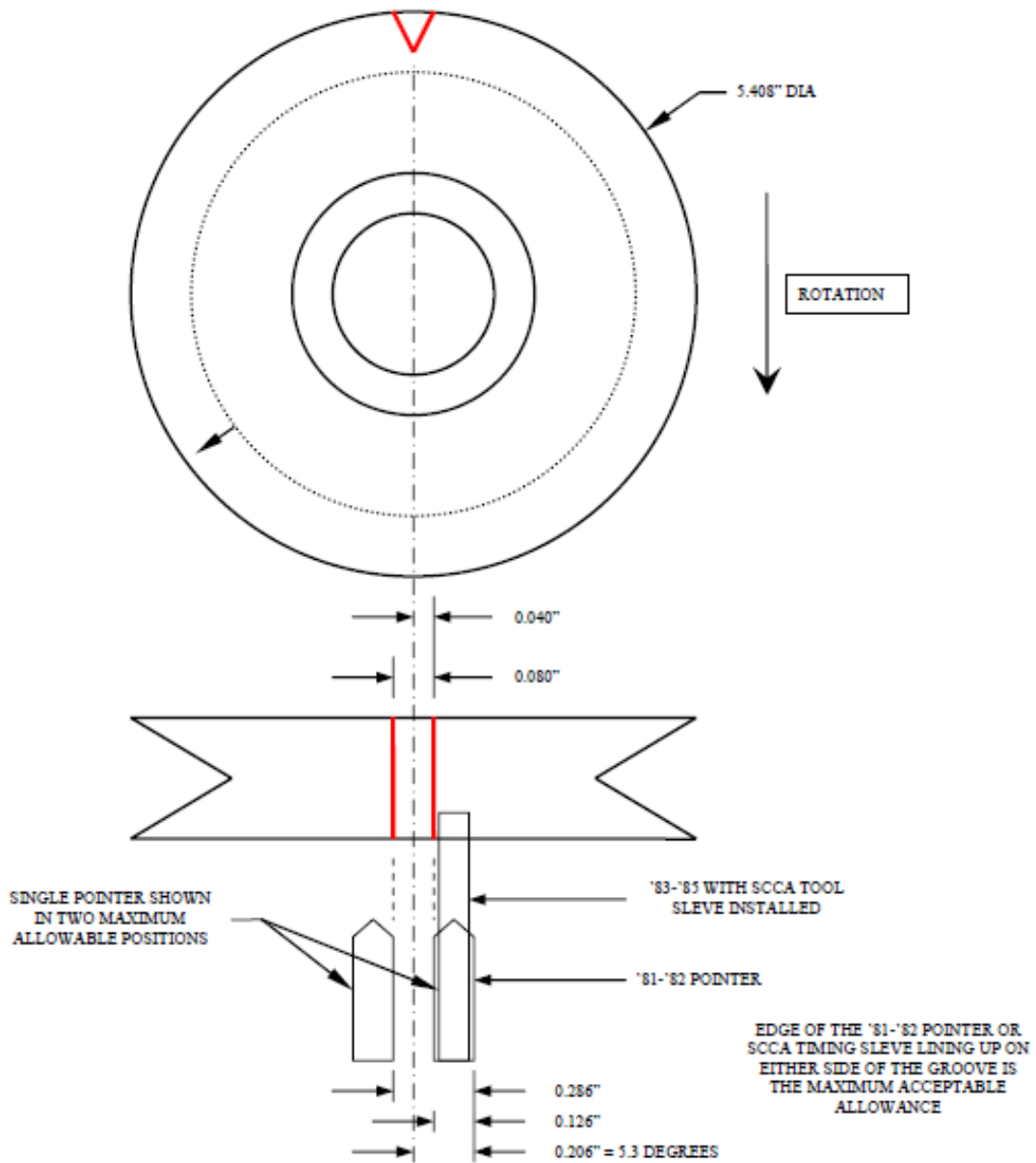

Figure 1: Ignition Timing Diagram

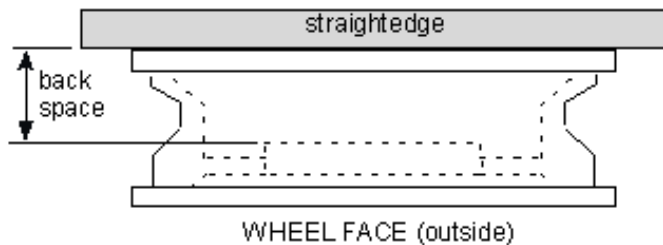

Figure 2: Wheel Back Space Diagram